

AE-SMDG-LC-40-I

1.25G Industrial SFP Transceiver

Features

- Up to 40km transmission on SMF
- Up to 1.25 Gbps
- 1550nm DFB laser and PIN receiver
- 2-wire interface for integrated Digital Diagnostic monitoring
- Hot pluggable
- Very low EMI and excellent ESD protection
- +3.3V power supply
- Power consumption less than 1.0W
- Operating case temperature: -40~+85°C



Description

AE-SMDG-LC-40-I is a high performance, cost effective modules, which is supporting up to 1.25Gbps, and transmission distance up to 20km on SM fiber. The transceiver consists of two sections: The transmitter section incorporates a laser driver and a 1550nm DFB laser. The receiver section consists of a PIN photodiode integrated with a transimpedance preamplifier (TIA) and a Limiting Amplifier. The module is hot pluggable

into the 20-pin connector. The high-speed electrical interface is base on low voltage logic, with nominal 100Ohms differential impedance and AC coupled in the module.

The optical output can be disabled by LVTTTL logic high-level input of TX_DIS. Transmit Fault (Tx_Fault) is provided to indicate that the module transmitter has detected a fault condition related to laser operation or safety. Loss of signal (RX_LOS) output is provided to indicate the loss of an input optical signal of receiver. A

serial EEPROM in the transceiver allows the user to access transceiver monitoring and configuration data via the 2-wire SFP Management Interface. This interface uses a single address, A0h, with a memory map divided into a lower and upper area. Basic digital diagnostic (DD) data is held in the lower area while specific data is held in a series of tables in the high memory area.

Applications

- High-speed storage area networks
- Computer cluster cross-connect
- Custom high-speed data pipes

Compliance

- Compliant with IEEE 802.3Z
- Compliant with MSA SFF-8472
- Compliant with SFP MSA

AE-SMDG-LC-40-I

1.25G Industrial SFP Transceiver

Specification

Absolute Maximum Ratings

Parameter	Symbol	Min.	Max.	Unit	Notes
Storage Temperature	T _s	40	+85	°C	
Supply Voltage	V _{CC3}	0	3.6	V	
Relative Humidity	RH	5	+85	%	Note1
Rx Input Average Power	P _{max}	-	+1	dBm	

Notes:

[1] Non-condensing state.

Recommended Operating Conditions

Parameter	Symbol	Min.	Typical	Max.	Unit
Operating Case Temperature	T _s	-40	-	+85	°C
Power Supply Voltage	V _{CC3}	3.13	3.3	3.47	V
Total Supply Current	I _{CC3}	-	-	300	mA
Power Dissipation	P _D	-	-	1.0	W
Data Rate			1.25		Gbps

Transmitter Operating Characteristic Optical, Electrical

Parameter	Symbol	Min.	Typical	Max.		
Centre Wavelength	λ _c	1500	1550	1580	nm	
Spectral Width	Δλ			1	nm	DFB
Average Optical Power		-7		0	dBm	
Laser Off Power	P _{off}	-	-		dBm	
Extinction Ratio		8.2		-	dB	
Operating Data Rate		-	1.25	-	Gbps	
Optical Eye Mask	Compliant with 802.3ah eye masks when filtered					
Tx Input Diff. Voltage		500	-	2400	mV	
Tx Fault Output Voltage -- Low		-0.3	-	0.4	V	
Tx Fault Output Voltage -- High		2.4	-	V _{cc} +0.3	V	

AE-SMDG-LC-40-I

1.25G Industrial SFP Transceiver

Specification

Receiver Operating Characteristic Optical, Electrical

Parameter	Symbol	Min.	Typical	Max.	Unit	Note
Centre Wavelength	λ_r	1260	1550	1610	nm	
Spectral Width	Psen	-	-	-24	dBm	
Average Optical Power	LosA	-35	-	-	dBm	
Laser Off Power	LosD	-	-	-25	dBm	
Extinction Ratio	LosH	0.5	-	-6	dB	
Operating Data Rate	Pin	-	-	-3	dBm	
Optical Eye Mask	Vo	-	-	2000	mV	
Tx Input Diff. Voltage	-	-	1.25	-	Gbps	

Digital Diagnostic Functions

Parameter	Symbol	Min.	Max.	Unit	Notes
Temperature monitor absolute error		-3	3	°C	Over operating temp
Laser power monitor absolute error	DMI_TX	-3	3	dB	
RX power monitor absolute error		-3	3	dB	
Supply voltage monitor absolute error	DMI_VCC	-3%	+3%	V	
Bias current monitor absolute error		10%	10%	mA	

Control and Status I/O Timing Characteristics

Parameter	Symbol	Min.	Max.	Unit	Notes
TX Disable Assert Time	t_off	-	100	µs	Note1
TX Disable Negate Time	t_on	-	2	ms	Note2
Time to initialize including reset of TX_Fault	t_init	-	300	ms	Note3
TX Fault Assert Time	t_fault_on	-	1	ms	Note4
TX Fault Reset Time	t_reset	10	-	µs	Note5
LOS Assert Time	t_loss_on	-	100	µs	Note6
LOS Deassert Time	t_loss_off	-	100	µs	Note7

Notes:

- Time from rising edge of TX Disable to when the optical output falls below 10% of nominal
- Time from falling edge of TX Disable to when the modulated optical output rises above 90% of nominal
- From power on or negation of TX Fault using TX Disable
- Time from fault to TX fault on
- Time from TX fault to TX nominal
- Time from LOS state to RX LOS assert
- Time from non-LOS state to RX LOS datasheet

AE-SMDG-LC-40-I

1.25G Industrial SFP Transceiver

Pin-out Definition

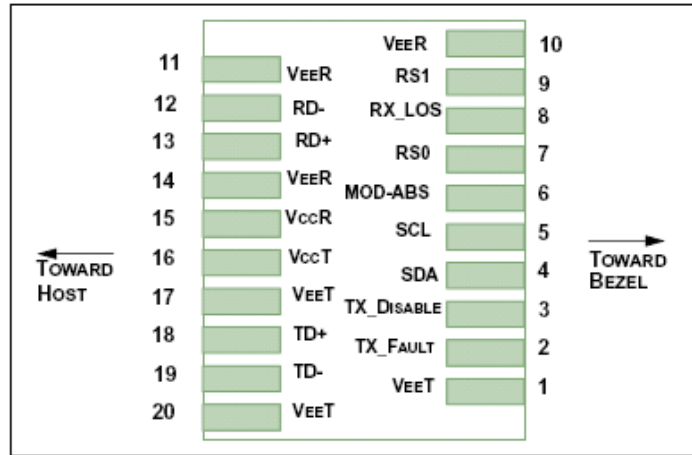

Figure 1

Pin Assignment

Pin	Logic	Symbol	Name/Description	Note
1			Module Transmitter Ground	
2	LVTTTL-O	TX_Fault	Module Transmitter Fault	
3	LVTTTL-I	TX_Disable	Transmitter Disable; Turns off transmitter laser output	
4	LVTTTL-I/O	SDA	2-wire Serial Interface Data Line (Same as MOD-DEF2 as defined in the INF-8074i)	
5		SCL	2-wire Serial Interface Clock (Same as MOD-DEF1 as defined in the INF-8074i)	
6		MOD_ABS	Module Absent, connected to VeeT or eeR in the module	
7	LVTTTL-I	RS0	Not used	
8	LVTTTL-O	RX_LOS	Receiver Loss of Signal Indication (In FC designated as RX_LOS, in SONET designated as LOS, and in Ethernet designated at Signal Detect)	
9	LVTTTL-I	RS1	Not used	
10		VeeR	Module Receiver Ground	
11		VeeR	Module Receiver Ground	
12	CML-O	RD-	Receiver Inverted Data Output	
13	CML-O	RD+	Receiver Non-Inverted Data Output	
14		VeeR	Module Receiver Ground	
15		VccR	Module Receiver 3.3 V Supply	
16		VccT	Module Transmitter 3.3 V Supply	
17		VeeT	Module Transmitter Ground	
18	CML-I	TD+	Transmitter Non-Inverted Data Input	
19	CML-I	TD-	Transmitter Inverted Data Input	
20		VeeT	Module Transmitter Ground	

AE-SMDG-LC-40-I

1.25G Industrial SFP Transceiver

Block Diagram Of Transceiver

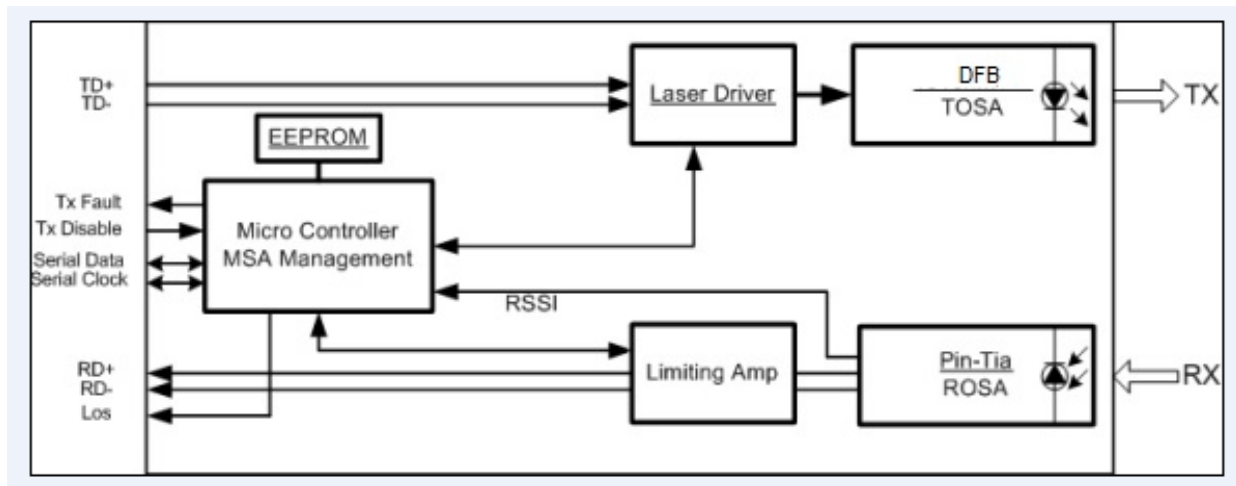

Transmitter Section

The transmitter converts 1.25Gbit/s serial PECL or CML electrical data into serial optical data compliant with the 1000BASE-LX standard. An open collector compatible Transmit Disable (Tx_Dis) is provided. A logic "1," or no connection on this pin will disable the laser from transmitting. A logic "0" on this pin provides normal operation. The transmitter has an internal automatic power control loop (APC) to ensure constant optical power output across supply voltage and temperature variations. An open collector compatible Transmit Fault (Tx_Fault) is provided. TX_Fault is a module output contact that when high, indicates that the module transmitter has detected a fault condition related to laser operation or safety. The TX_Fault output contact is an open drain/collector and shall be pulled up to the Vcc_Host in the host with a resistor in the range 4.7-10 kΩ. TX_Disable is a module input contact. When TX_Disable is asserted high or left open, the SFP module transmitter output shall be turned off. This contact shall be pulled up to VccT with a 4.7 kΩ to 10 kΩ resistor

Receiver Section

The receiver converts 1.25Gbit/s serial optical data into serial PECL/CML electrical data. An open collector compatible Loss of Signal is provided. Rx_LOS when high indicates an optical signal level below that specified in the relevant standard. The Rx_LOS contact is an open drain/collector output and shall be pulled up to Vcc_Host in the host with a resistor in the range 4.7-10 kΩ, or with an active termination. Power supply filtering is recommended for both the transmitter and receiver. The Rx_LOS signal is intended as a preliminary indication to the system in which the SFP is installed that the received signal strength is below the specified range. Such an indication typically points to non-installed cables, broken cables, or a disabled, failing or a powered off transmitter at the far end of the cable.

AE-SMDG-LC-40-I

1.25G Industrial SFP Transceiver

Recommended Interface Circuit

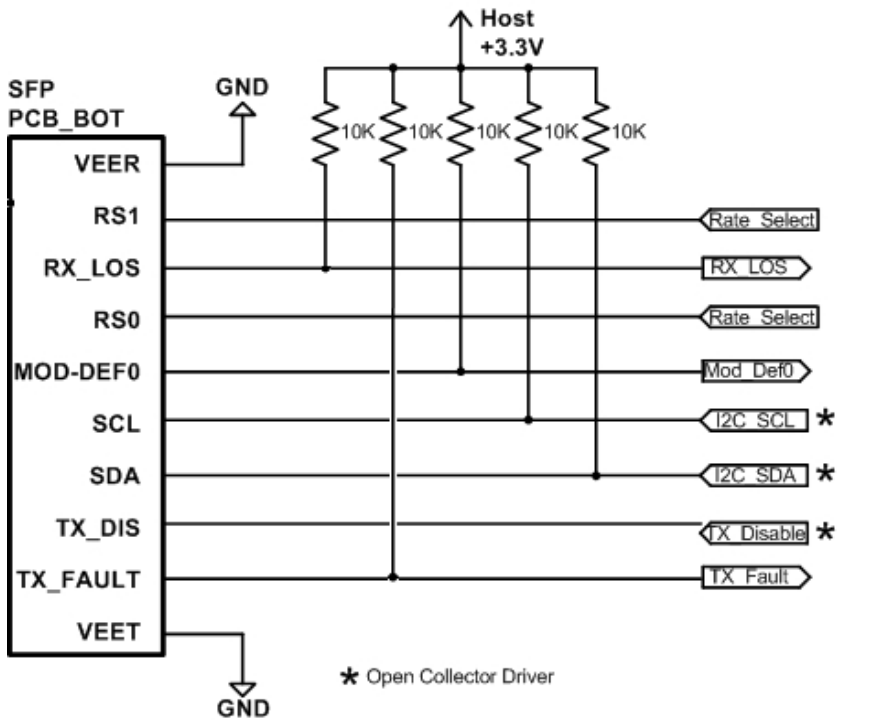
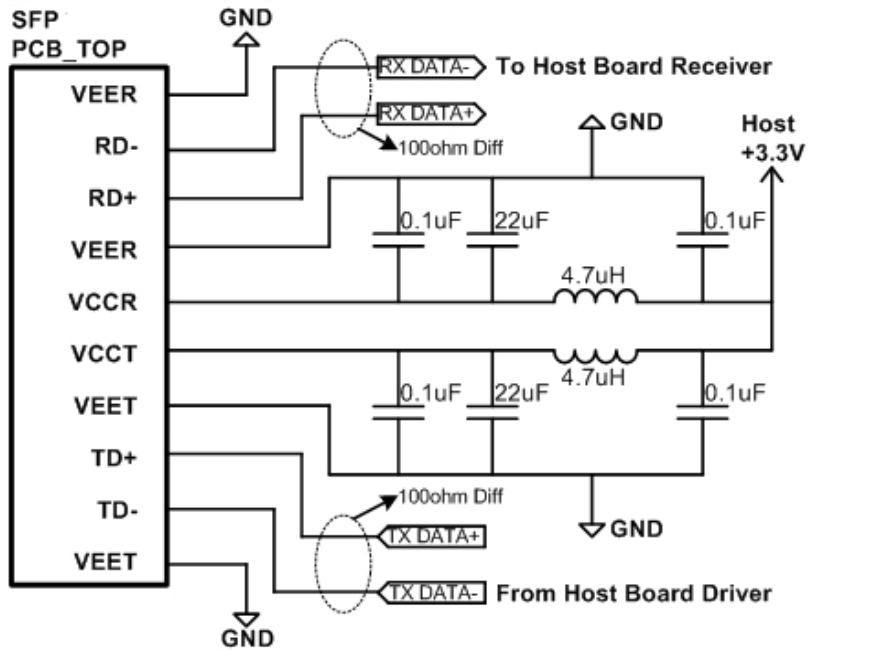

AE-SMDG-LC-40-I

1.25G Industrial SFP Transceiver

Dimensions

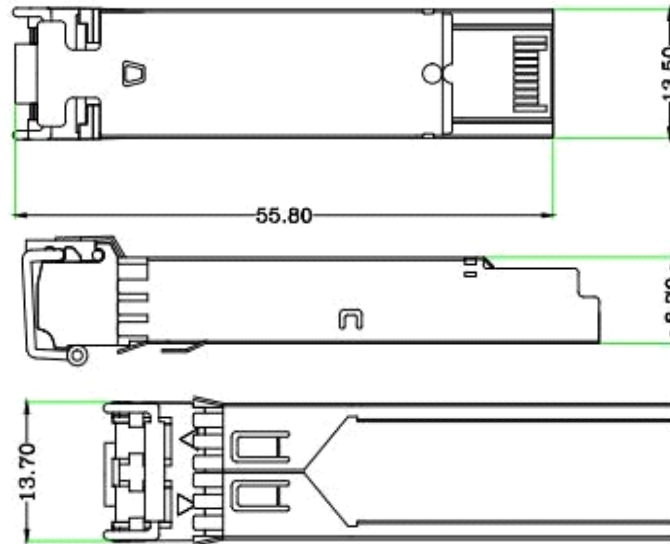

Tolerance: X.X±0.10X.XX±0.05X.XXX±0.01

Figure4

Digital Diagnostic Memory Map

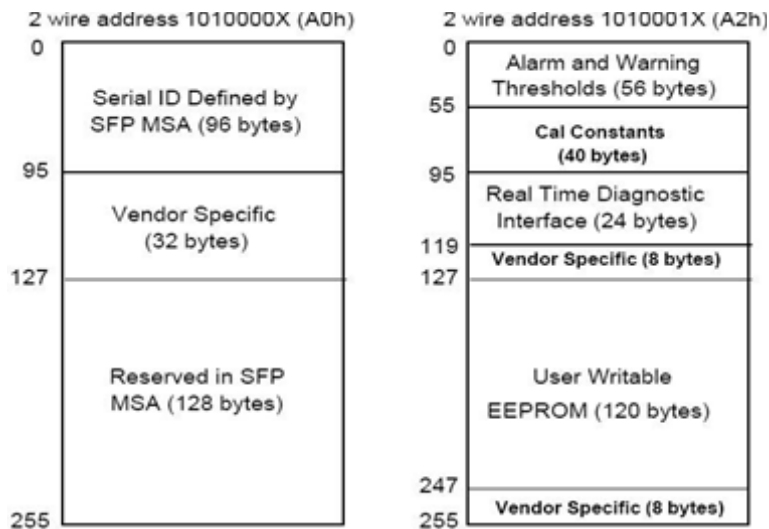

Figure5

Notice

Performance figures, data and any illustrative material provided in this data sheet are typical and must be specifically confirmed in writing by AE Connect before they become applicable to any particular order or contract. In accordance with the AE Connect policy of continuous improvement specifications may change without notice. The publication of information in this data sheet does not imply freedom from patent or other protective rights of AE Connect or others. Further details are available from any AE Connect sales representative.